

# Unit Five

## Life on the Seas and Rivers

### Index

Activity 1: Art, Music, Literature, and the Sea.....108	Activity 4: Knots.....114 Worksheet: Eight Knots .....5E
Activity 2: Boat and Nautical Language .....110 Worksheets: Captains Know Their Boats .....5A Ship Ahoy!.....5B	Activity 5: Tides.....115 Worksheet: Tides .....5F
Activity 3: Navigation .....111 Worksheets: Port of Anchorage Chart.....5C Nautical Knots .....5D	Activity 6: Boating Safety ..116 Worksheets: Putting Out to Sea.....5G Safety Afloat.....5H
	Activity 7: Sportfishing Trip.....118

### Objectives:

To help students:

- Explore the influence of the sea on art, music and literature (Activity 1).
- Express their feelings about the sea through poems, stories, watercolor paints, music and wood or soap carvings (Activity 1).
- Label the parts of a boat (Activity 2).
- Use nautical phrases (Activity 2).
- Read a nautical chart (Activity 3).
- Compute a variety of knotty problems (Activity 3).
- Tie eight different knots (Activity 4).
- Read a tide table (Activity 5).
- Graph local tides for a week or more (Activity 5).
- Plan necessary boat safety practices and equipment for their own boat (Activity 6).
- Wear life jackets and survival suits (Activity 6).
- Play a Safety Afloat Game (Activity 6).
- Survey local sportfish and their habits (Activity 7).
- Read sportfishing regulations (Activity 7).
- Practice sportfishing skills (Activity 7).

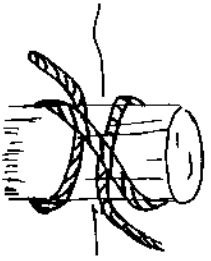
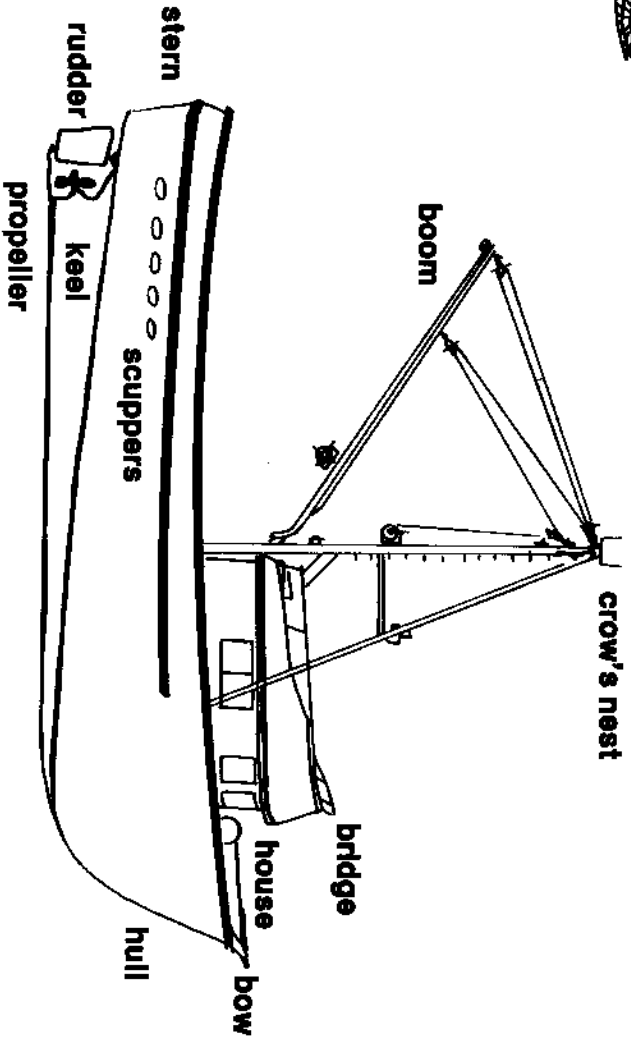
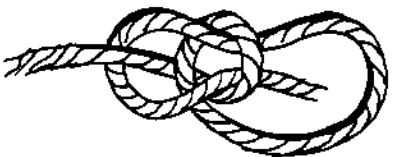
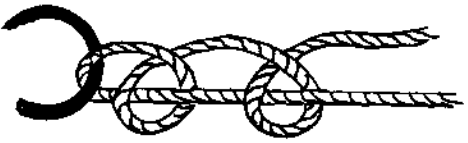
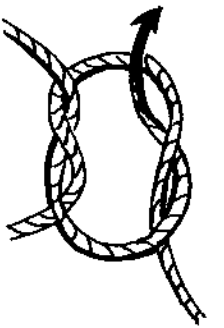
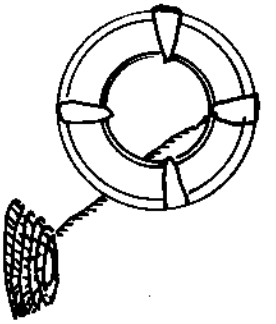

**Unit Five:** Sea ropes, clockwise from top left: life ring, square knot, figure eight on a cleat, bowline, sheet bend, figure eight, clove hitch, two half hitches.

Fishing is an old, old way of life. At its most basic, it is a way of getting food - a means of survival. Before people had supermarkets, even before fields were cultivated and seeds planted, people hunted and fished to obtain their food.

From earliest times, those people who set out in boats to fish have been aware of the risks involved. Fishing peoples past and present have pitted themselves and their frail vessels against the unpredictable, often violent, forces of wind and waves. Anyone who has ever fished or known people who fish can give accounts of vessels and people lost without a trace in stormy weather, of ships driven onto rocky shores, of crew members lost overboard. The sea and rivers can be hard masters that do not compromise or forgive mistakes.

Knowing the risks they take, many men and women still choose to make fishing their way of life. The reasons for such a choice are

many but high on the list would be a desire for independence, a desire to live close to the elements of nature, and a need to face challenge.

Risks and rewards of fishing have changed little over thousands of years. Modern technology has, of course, made some aspects of life at sea easier, but it has not yet tamed the elemental forces nor substantially reduced the risks. Modern fishermen and women draw upon knowledge and skills from generations before them. To these are added the latest electronic or mechanical products of our time. Survival and success at sea depend on knowledge drawn from many sources over many years.

Fishing consists of more than understanding and being able to operate a boat and its gear. For students to understand fishing as a way of life, they will need to explore some of the many areas of knowledge and skill fishing requires.

## Activity 1 Art, Music, Literature and the Sea

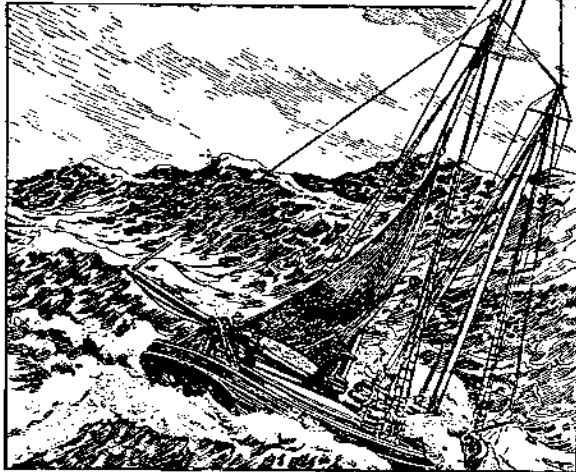

### Background:

The seas and rivers have powerful influences on most Alaskans, who receive most of their food and supplies from over the sea, if not from the sea itself. Many jobs are sea-related: The grocer stocks seafood products and sea-transported products; and dockhands, captains, boat builders and manufacturers of a multitude of boat and fishing equipment for the commercial, sport, and subsistence fisheries are all involved directly with the sea. In addition to supplying bodily needs, the sea has had a tremendous effect on the art, music, and literature, of our history and culture. This activity just barely opens the door (or the porthole) to a vast array of exciting reading, writing, painting and carving.

### Materials:

- sea and river poems and stories, paintings and carvings
- paper
- pencil
- watercolors

- brushes
- bar of soap or block of wood for each student
- knife for each student
- local artist

### Procedure:

1. To capture the spirit of "putting out to sea," share these poems and others with your class; or sing a few sea chanties, read some of the stories listed in the bibliography, and bring carvings and paintings (such as those of Winslow Homer). Try to capture the mood of the sea. Imagine the ocean both in calm and stormy days, rain and sun. Mention the long hours at sea and that some sailors and fishermen filled by carving exquisite scrimshaw into ivory, keeping journals, or making sketches of sea life.

### Sea-Fever

I must go down to the seas again,  
to the lonely sea and the  
sky,  
And all I ask is a tall ship and a  
star to steer her by,  
And the wheel's kick and the  
wind's song and the white  
sail's shaking,  
And a grey mist on the sea's face  
and a grey dawn breaking.

I must go down to the seas again,  
for the call of the running  
tide  
Is a wild call and a clear call that  
may not be denied;  
And all I ask is a windy day with  
the white clouds flying,  
And the flung spray and the blown  
spume, and the sea-gulls  
crying.

I must go down to the seas again

to the vagrant gypsy life,  
To the gull's way and the whale's  
way where the wind's like a  
whetted knife;  
And all I ask is a merry yarn from  
a laughing fellow-rover,  
And quiet sleep and a sweet dream  
when the long trick's over.

by John Masefield

---

The Sea to a Sailor

Blue green water  
stretching forever  
ebbing gently  
whispering  
slipping by  
broken only by the distant  
white  
of seagulls.

Then suddenly  
the fish jumps  
the solemnity is shattered  
the ripples laugh  
silver bubbles burst  
then slowly  
silently  
the calm returns  
to reign  
once more.

by John Hannah,  
a British Columbia student

---

Poem of the Wintery Fisherman

At the foot of October  
where the current narrows,  
the salmon wait,  
Burning in the shallows -  
  
blood-red, green and orange,  
in the ice-blue glacier water.

Listen! you can hear  
the long, slow pull of slush

against the banks,  
deep rumble of stones.

I stand alone in the smoking  
frost, a long hook poised,  
and fling the bright fish up  
the pebbled, icy bar  
to quiver and lie still,  
a sinking fire.

Sometimes the cold eggs spill  
in the snow, glowing  
like the eyes of foxes who wait  
at sundown, when I shoulder  
my catch and mount  
the frozen twilight homeward.

Along the darkening river,  
ravens grip their iron twigs,  
shadows of  
the hungry, shuddering night.

by John Haines, Alaskan poet  
from Winter News, p. 61

2. Then have students try to express their own feelings with watercolors; soap or wood carvings; poems; stories; music. Invite local artists, musicians, poets, and authors to share their experiences with your class and assist the students in their projects.

Fish  
Gold red  
It eats animals  
Lives in the sea  
Diving and swimming  
Salmon, halibut, fish.

by Cherish Carroll, (Gerry Young,  
teacher) University Park Elementa-  
ry, Fairbanks)

## Activity 2 Boat and Nautical Language

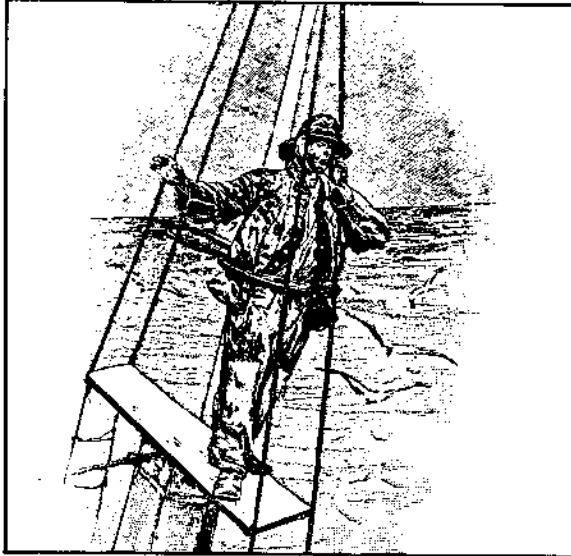

### Background:

Boat terminology and language have developed over the centuries. In times of emergency, many seconds of valuable time can be saved by using correct and precise terms.

### Vocabulary:

- keel
- hull
- house
- mast
- boom
- bow
- stern
- port
- flying bridge
- crow's nest
- starboard
- rudder
- propeller
- aft
- aboard
- aloft
- below
- deck
- hatch
- scuppers

- galley
- head
- batten
- shipshape
- bilge
- stow
- list
- bunk
- helm
- line
- cast off
- belay
- P.F.D.

### Materials:

- model boat
- paper
- pencils
- worksheets:
  - ...Captains Know Their Boats (5A)
  - ...Ship Ahoy (5B)

### Procedure:

1. Ask students to think of nautical terms and share them with the class. Pass out the worksheet Captains Know Their Boats and have students label the parts. (Answers: a: bow; b: starboard; c: port; d: stern; e: bridge; f: house; g: hull; h: crow's nest; i: boom; j: scuppers; k: keel; l: rudder; m: propeller.) Use a model boat in the discussion afterwards to assist students in visualizing all the features.
2. Share this boat poem with students as a sample of what happens when a part is forgotten!

### Homemade Boat

This boat that we just built is just fine -  
And Don't try to tell us it's not.

The sides and the back are divine  
It's the bottom I guess we for-  
got....

by Shel Silverstein

3. Then try out nautical phrases with the students. Pass out the worksheet Ship Ahoy. (Answers: 1: e; 2: i; 3: d; 4: j; 5: l; 6: g; 7: f; 8: k; 9: m; 10: b; 11: a; 12: p; 13: n; 14: h; 15: o; 16: c.)
4. Begin a class collection of nautical terms and phrases. Have students write short humorous paragraphs or poems using as many nautical terms as possible.

---

### Activity 3 Navigation

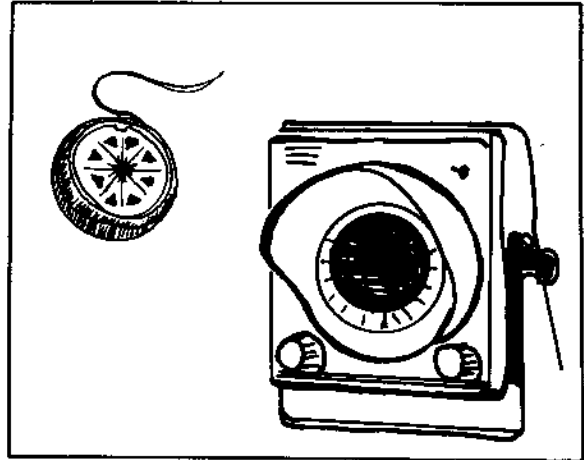

#### Background:

Navigation is a complex science, but its basic concept can be conveyed through the relatively easy skill of reading a chart. Landlubbers have maps which delineate roads, cities, and political boundaries. Charts emphasize natural and man-made features of interest to a navigator. To travel anywhere safely, a skipper must have knowledge of water depths, shoals, channels, and where ports and harbors are located. This information can be gained only from other local residents, or through long experience in an area, or by reading a chart. For details in navigation or chart reading, use Chapman's Piloting, Seamanship and Small Boat Handling.

#### Vocabulary:

- chart
- scale
- compass rose
- declination
- latitude
- longitude
- navigational aids

## Materials:

- local charts
- compasses
- pieces of string
- pencils
- copies of local charts
- electronic navigational equipment
- worksheets:
  - ...Port of Anchorage Chart (5C)
  - ...Nautical Knots (5D)

## Procedure:

1. Obtain a nautical chart of your area from a government agency, store, local resident, or order one from National Ocean Survey Chart Sales and Geodetic Control, Federal Building and U.S. Court House, 701 C Street, Box 38, Anchorage, Alaska 99513. Make copies of portions of the chart and develop questions for the students to answer. Use the worksheet Port of Anchorage Chart as an introduction. You'll need to tape the two sheets of the chart together. (Answers: 1: starboard, port; 2: hard, rock; 3: 66 feet; 4: port; 5: 140 feet, equal intervals 6 seconds light; 6: port; 7: draw a line so that the boat has more than 6 fathoms of water.) For more information, check Tidelines, "The Port That Grew in the Wrong Place," Vol. III, No. 3, November 1980.
2. Go over the following terms and information about navigational aids:
  - Scale indicates distances. A chart is a representation in miniature of a certain area. Actual distances must be

"scaled down." Have students calculate distances between different points on their charts by using a piece of string to measure the distance, and then comparing it to the equivalency scale. Note that from the scale on the Port of Anchorage chart that distances are given in nautical miles as well as statute (or land) miles. 1 nautical mile = 1.15 statute miles, so nautical miles are just a little longer. The worksheet Knotty Problems contains a few computations for your students using nautical miles and boat speeds. (Answers: 1: 5 hours; 2: 70 nautical miles; 3: 6 knots; 4: \$15.)

- A Compass Rose is the star shape printed on maps to indicate the 64 compass points (Some compass roses contain only 32 points, some 16, and some eight: North, Northeast, East, Southeast, South, Southwest, West, and Northwest). A student using a map and compass should spread the map on a flat surface, then rotate it so that its compass rose point indicating magnetic north is pointing the same direction as the compass needle.
- Latitude and longitude are indicators of exact location on the earth's surface. The whole world is divided like graph paper with longitude lines running north and south, and latitude lines running east and west. Have students find the latitude and longitude lines on their charts. Ask the students:

- Where are the 0° latitude



and longitude located? (They should be able to tell by looking at their charts that the 0° longitude is east and the 0° latitude is south. Latitude starts at the equator and longitude starts on a line that runs through Greenwich, England.)

- Depths on the Pacific Coast are listed in fathoms (1 fathom = 6 feet) at the "mean lower low water." The definition of mean lower low water is the average of all the lowest water levels for tidal days over a period of time. Have students find the deepest spots on their charts. Then have them change those readings to feet. For example, if the depth is 6 fathoms, it would translate to 36 feet.
- Natural and man-made features are marked throughout the chart. Have students look for uncovered rocks; bottom types (Knowing whether a bottom is sandy, rocky or muddy is important to

know for anchoring), wrecks, snags or stumps. Note the land contours which show heights of mountains and other landmarks that a person might be able to see briefly through the fog! Have students make a class list of all the different markings.

- Navigational aids are a variety of markers that help people traveling in seas and large rivers. Buoys are used to indicate channels. There is a little phrase students should know: "Red right returning." When anyone's coming into the harbor, all the red buoys should be on their right.
3. Research old and new ways of navigation. Invite village elders, a long-time fisherman or woman, someone from the Coast Guard, a Sea Grant Marine Advisory agent or a marine supply owner to go over old-time and the latest electronic navigational equipment. Your class may want to visit a boat or marine supply store, or look at marine catalogs.

## Activity 4 Knots

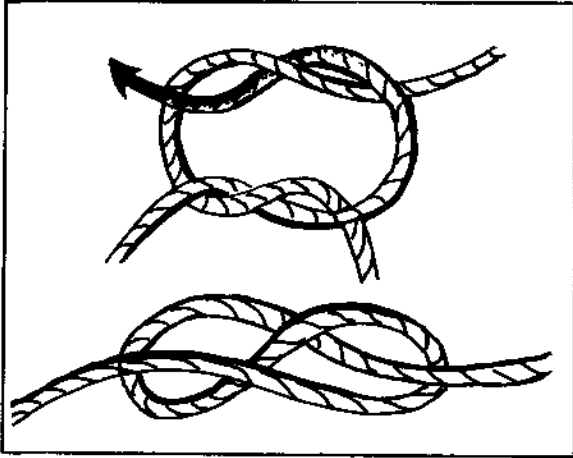

### Background:

Knowing knots is critical to anyone who spends any time around water. Fishermen and other boat handlers should know knots so well that they can tie them in the dark and blindfolded! Knots often must be able to hold under adverse weather conditions, yet untie easily. And that's sometimes tough when they are wet and frozen. Every smart fisherman or woman always carries a knife to cut the lines quickly in an emergency.

### Materials:

- 2 pieces of string or line per student
- several cleats mounted on wooden boards
- small log or chair leg
- ring or coat hanger
- scissors
- colored pencils
- worksheet:  
...Eight Knots (5E)

### Procedure:

1. Collect two pieces of string or line for each student, several small logs or chair legs, rings or coat hangers pulled out of shape, and colored pencils. Attach several cleats to boards (devise imitation cleats out of pieces of wood if you don't have the real thing).
2. Explain to students that they'll need to know these knots for their next ocean or river voyage! Then pass out copies of the worksheet Eight Knots and two pieces of string per student. Remind students that on a boat, ropes are called "lines." The students may want to shade each line a different color on the drawings of the square knot and sheet bend so that they can tell where each line goes. Have students cut out the pictures of the different knots to make little cards, then practice tying.
3. After the students practice, call out the different knots and see how fast their hands can move. Check for knot accuracy throughout the session. Discuss situations in which each knot would be needed, such as "The line was rapidly slipping through my partner's hands as he tried to hold our skiff, which was being pulled away by a fierce rip tide (strong current). I quickly grabbed the end of the line and wrapped it in a figure eight around a cleat."

## Activity 5 Tides

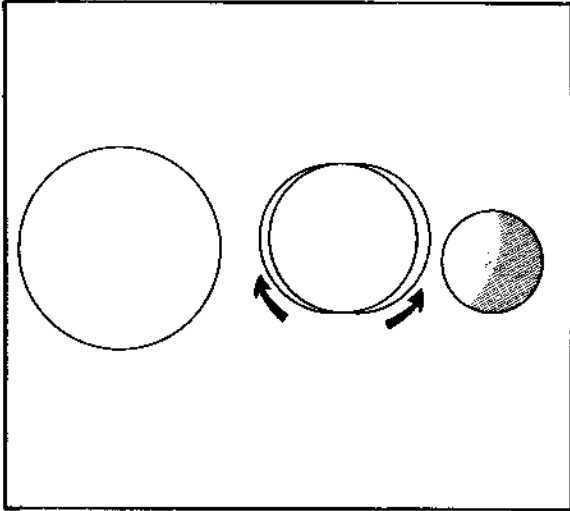

### Background:

Tides are important to fishermen. Some places may be better to fish at a particular stage of the tide and may even be impossible to fish if the tide is ebbing or flooding too strongly. When fishing, a boat operator must always be aware of whether the tide is flooding or ebbing and must operate the boat and the fishing gear accordingly. Everybody fishing carries one or more tide books and often a book showing tidal currents as well.

Tides are caused by the gravitational pull of the moon and the sun on the earth's surface. The moon, because it's closer to the earth, exerts the strongest pull. As a result, the side of the earth (a) closest to the moon will have higher tides than the side closer to the sun (b). Water is pulled from the intermediate areas (c and d) to form the high tides, so these areas will have low tides. The earth is continually spinning so that areas c, d, e and f alternate between low and high tides.

The average highs and lows vary in different areas because of land formations and ocean currents. Cook Inlet has the greatest tidal range in Alaska and the second highest worldwide. Sometimes the Cook Inlet tide varies 40 feet from low to high tide. Yet the tides are almost nonexistent along the shores of the Bering Sea and other northern coast areas of Alaska.

### Materials:

- tide tables, one per student if possible
- worksheet:  
... Tides (5F)

### Procedure:

1. Obtain tide tables for each student or at least enough so that every two or three students will have one to share. Banks, marine supply, and sporting goods stores often distribute tide tables free or at a nominal cost.
2. As a class, review the causes of tides and then spend time looking through the tide books and discussing the kinds of information they contain. If possible, look at tidal information for a location near your community. Ask the students:
  - When is there a low tide today?
  - When is there a high tide?
  - When is the highest tide of the month?

If the tide book contains information on the combined effect of wind and temperature, discuss the importance

wind chill tables. If you live near a marked channel, and channel marker information is included in your tide books, review the colors and markings of navigational aids.

- Distribute the worksheet Tides and allow time for students to complete the answers to the questions. (Answers: 1: 12.7; 2: .09; 3: 8:59 a.m. and 9:06 p.m.; 4: 6:53 a.m. and 7:39 p.m.; 5: Nov. 5; 6: Nov. 5; 7: 9.4 feet.)

HIGH Tides CORDOVA District NOVEMBER 1983					LOW Tides CORDOVA District NOVEMBER 1983						
DATE	DOT #	A	M	FT.	DATE	DOT #	A	M	FT.		
1 Tues	●	9:36	12.7	9:09	12.2	1 Tues	●	3:06	0.9	3:43	1.7
2 Wed	●	10:16	13.6	10:42	12.6	2 Wed	●	3:54	0.5	4:31	0.0
3 Thur	●	10:56	14.4	11:33	12.9	3 Thur	●	4:40	0.4	5:14	-1.3
4 Fri	●	11:32	14.8	.....	.....	4 Fri	●	5:19	0.6	5:56	-2.1
5 Sat	●	0:19	12.9	12:07	15.0	5 Sat	●	5:59	1.1	6:36	-2.4
6 SUN	●	1:03	12.7	12:42	14.8	6 SUN	●	6:36	1.9	7:18	-2.1
7 Mon	●	1:45	12.2	1:15	14.3	7 Mon	●	7:15	2.8	7:55	-1.5
8 Tues	●	2:31	11.6	1:49	13.5	8 Tues	●	7:54	3.8	8:37	-0.5
9 Wed	●	3:13	10.9	2:29	12.5	9 Wed	●	8:39	4.8	9:21	0.5
10 Thur	●	4:09	10.2	3:08	11.4	10 Thur	●	9:24	5.6	10:09	1.6
11 Fri	●	5:18	9.7	4:04	10.3	11 Fri	●	10:20	6.2	11:05	2.5
12 Sat	●	6:32	9.6	5:34	9.3	12 Sat	●	11:28	6.5	.....	.....
13 SUN	●	7:34	9.8	7:03	8.3	13 SUN	●	0:09	3.1	12:56	6.1
14 Mon	●	8:21	10.4	8:13	8.6	14 Mon	●	1:23	3.2	2:23	5.1
15 Tues	●	8:59	11.0	8:06	10.0	15 Tues	●	2:24	3.0	3:16	3.7
16 Wed	●	9:33	11.7	9:54	10.5	16 Wed	●	3:14	2.7	3:57	2.3
17 Thur	●	10:07	12.5	10:42	10.9	17 Thur	●	3:54	2.4	4:31	0.9
18 Fri	●	10:39	13.2	11:24	11.4	18 Fri	●	4:31	2.2	5:04	-0.3
19 Sat	●	11:09	13.8	.....	.....	19 Sat	●	5:03	2.1	5:40	-1.3
20 SUN	●	0:07	11.7	11:44	14.3	20 SUN	●	5:39	2.3	6:19	-1.9
21 Mon	●	0:47	11.8	12:17	14.5	21 Mon	●	6:17	2.6	6:57	-2.1
22 Tues	●	1:30	11.8	12:53	14.5	22 Tues	●	6:53	3.1	7:36	-2.0
23 Wed	●	2:13	11.6	1:30	14.2	23 Wed	●	7:38	3.6	8:25	-1.6
24 Thur	●	3:03	11.2	2:15	13.6	24 Thur	●	8:26	4.2	9:16	-0.9
25 Fri	●	4:00	10.8	3:07	12.8	25 Fri	●	9:21	4.7	10:09	-0.2
26 Sat	●	5:12	10.7	4:21	11.5	26 Sat	●	10:27	4.9	11:09	0.6
27 SUN	●	6:21	10.9	5:56	10.7	27 SUN	●	11:41	4.8	.....	.....
28 Mon	●	7:23	11.5	7:22	10.5	28 Mon	●	0:15	1.3	1:05	4.0
29 Tues	●	8:14	12.3	8:35	10.8	29 Tues	●	1:23	1.7	2:25	2.6
30 Wed	●	9:02	13.1	9:30	10.9	30 Wed	●	2:29	1.9	3:27	1.0

CO-11  
\* BIGGER THE DOT - BETTER THE FISHING

STANDARD TIME CO-11

- Using the tide tables obtained for the class, have students graph the tides for your area for one or more months. Label the vertical scale in feet and the horizontal scale in days of the month. Have each student plot one week or one month of tidal activity. Then the charts of all students can be combined, if the same scale is used, to show tidal changes over a longer period.

## Activity 6 Boating Safety

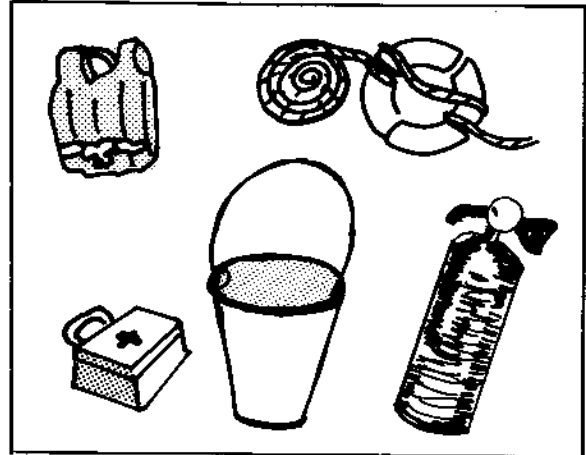

### Background:

The risks of fishing, being aboard a vessel at sea, or running a skiff up a river can be reduced by boating safety practices. Many students already are involved in commercial, subsistence and sport-fishing or in recreational boating, so knowing about safety precautions can be of real practical importance.

### Vocabulary:

- radar
- fathometer
- VHF
- bilge pump
- bailer

### Materials:

- paper
- pencils
- life jackets (P.F.D.s) and survival suits
- safety afloat net, safety afloat equipment, safety afloat playing cards
- fishermen's newspapers and magazines and marine supply catalogs
- Coast Guard representative or

Sea Grant Marine Advisory Agent

• worksheets:

...Putting Out to Sea (5G)

...Safety Afloat (5H)

1. Ask students what safety equipment they take with them on boat trips. Ask them about other safety equipment with which they're familiar. Then distribute the worksheet Putting Out To Sea and any fishing newspapers, magazines, marine supply catalogs that you have available. Look in the bibliography for suggestions. The worksheet asks students to draw a picture of a large or small boat they'd like to own and add and label all the necessary safety equipment. If there are enough catalogs, they can figure safety equipment costs.
2. Go over each item on the worksheet and discuss safety needs in terms of local conditions. You might want to add extra rain gear and warm clothes to the list of safety needs. Have the students try on life jackets and survival suits. Invite someone from the Coast Guard or a Sea Grant Marine Advisory Agent to demonstrate equipment and mention stories of people who had to use some of these safety items.
3. As a review, make up sets of the Safety Afloat card game worksheet for students to

play. It is similar to "pick-up sticks"--only students pick up safety equipment, naming each item before picking it up with their boat hooks.

#### Additional Activities:

1. Physical Education: Have life jacket relays in the gym or swimming pool. Stress the need to take special care of jackets because they may be needed to save lives. Never sit on a jacket; sew up rips immediately; and replace jackets when they show signs of wear. Have students practice putting them on in and out of the water. Remind students that life jackets are made to be worn. They won't do any good sitting in a locker.
2. Art: Have students make a safety collage with pictures of safety equipment from magazines and newspapers.
3. Language Arts: Encourage students to interview people who have had close calls, asking what happened and what they would have done differently. Then have students write stories and read them to the rest of the class.
4. Language Arts, Science, Art: Arrange for students to tour a boat and make a drawing of where all its safety equipment is located.

## Activity 7 Sportfishing Trip

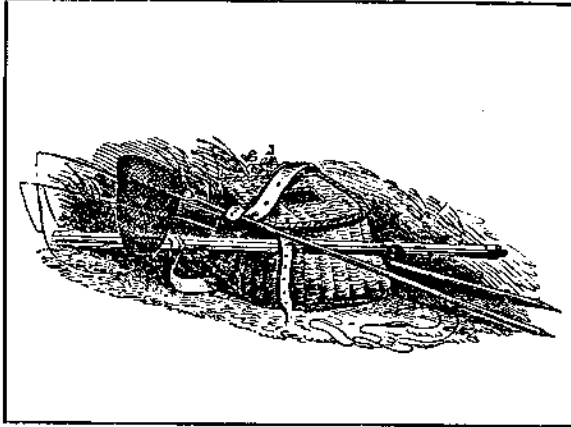

### Background:

A fishing trip may be just the thing needed to spark your students' interest in fisheries. It can be a good review of what a fish is, how it lives, what it looks like and how it behaves, plus a chance to practice the nautical skills covered in this unit.

More than 200,000 anglers fish Alaska annually, harvesting about 2½ million fish. Sportfishing is important to Alaska's economy, and is one of the state's main tourist attractions. About 25 percent of the total number of anglers are non-residents. The Kenai River is one of the most heavily fished rivers in the United States. And fish caught sportfishing form an important food base for many Alaskan households.

### Materials:

- pencils
- chalkboard
- chalk
- art supplies
- poles, lines, hooks and dip nets (if applicable) for students to use or share in pairs

- bait or lures
- knife
- pliers
- stringer or sack to hold the fish
- warm clothing and rain gear
- sportfishing regulations
- sport fisherman or woman
- Fish and Wildlife protection officer
- small group leaders

### Procedure:

1. Make a chart to survey local fish and fish habitats. Give students individual copies of the chart and have them talk to biologists, their parents and other local resource people about fish. Then compile a big class chart on the board of everyone's

Name of Fish	How It's Identified	How It's Caught	Where It's Caught	Time of Year Caught
1.				
2.				
3.				
4.				
5.				

answers. (This chart was suggested by Mary Couche, Kivalina)

2. Invite sport fishermen or women to explain and demonstrate their techniques. Also check Volume 2 of the Sea Week Curriculum Series for information on sportfishing lures and how they are developed to look like aquatic insects.
3. Involve students in planning the trip. Have them help get the equipment together (or make it), develop safety rules, read the tide tables and nautical charts, plan a

nutritious snack or lunch, invite parents, resource people, or older students to come along as small group leaders, send home permission slips. You might want to consider taking part of the class at a time, or fishing on a well-lighted dock at night (as lights often attract fish so that they can more easily be seen and caught).

4. Discuss conservation of fish and the need for fishing regulations. Read some of the local sport fishing regulations. Write to the Sport Fish Division, Alaska Department of Fish and Game, Box 3-2000, Juneau, Alaska 99802 for a copy of the regulations, or pick them up at wherever fishing licenses are sold in your community. Invite a local fish and wildlife protection officer to talk with the class.

Why is fish habitat important? What has happened to sport fishing opportunities in the Lower 48? What has happened to fish habitats there? (Mention filling and dredging, channelization, housing, roads, logging, dams.) Ask students what they can do to be sure there will be plenty of fishing for their children and grandchildren. This might be a good time to remind students that fish are a renewable resource. (Used wisely, fish will be here for generations to come.)

5. Study the fish you catch. If the fish are common in your area, be sure all students can name them and understand how to identify them. If you catch fish that they can't

identify, take them back to school and key them out, thumb through reference books until you identify them, or ask a local person familiar with fish. If you catch several different fish, compare their external features. What about color patterns? Are there any apparent differences in scales? What about placement of the fish's eye on the body? How do body shapes differ?

Stress to students the importance of not wasting a natural resource. If youngsters want to see a fish and study it, but have no further use for it, be sure it is carefully unhooked and returned alive to the stream. Keep only the fish you can use in further studies or for food. And remember, any time fish are handled, your hands should be wet to help prevent stripping the protective outer mucus layer of the fish.

If you plan to keep any of the fish, clean them right after they are caught. Have students identify internal structures as a review of what they have already learned. Be sure to open the stomach to see what the fish has been eating.

6. As a follow-up, have the students write stories, poems or music, and use a variety of art supplies to draw, paint or carve reminders of their fishing trip. Compare these projects to the ones developed at the unit's beginning. Was the actual fishing a real inspiration?

**Additional Activities:**

1. Art, Language Arts: Have students make up and draw cartoon stories about "the fish that got away." (Suggested by Tuck Mallory, Turnagain Elementary, Anchorage)
2. Language Arts: Have students prepare oral or written reports on big fish they have caught or want to catch. Write to the Alaska Department of Fish and Game,

Division of Sport Fish, P.O. Box 3-200, Juneau, Alaska 99802 for information about trophy fish award rules. The department awards 8"x10" parchment certificates to all contestants that win one of these awards. Certificates are given for fish of trophy weight, for the largest weight for the year; and for any new state records. The fish must be weighed, photographed, and an affidavit signed in the presence of a trophy fish official.



# Captains Know Their Boats

To fish, a person must know many things and have many skills. Among the most basic is how to talk about a boat.

Each part of a boat has a special name. Knowing these names makes it easier to talk about the boat. Here is a diagram of a boat and a list of terms and definitions used to describe its parts. See if you can label the parts correctly.

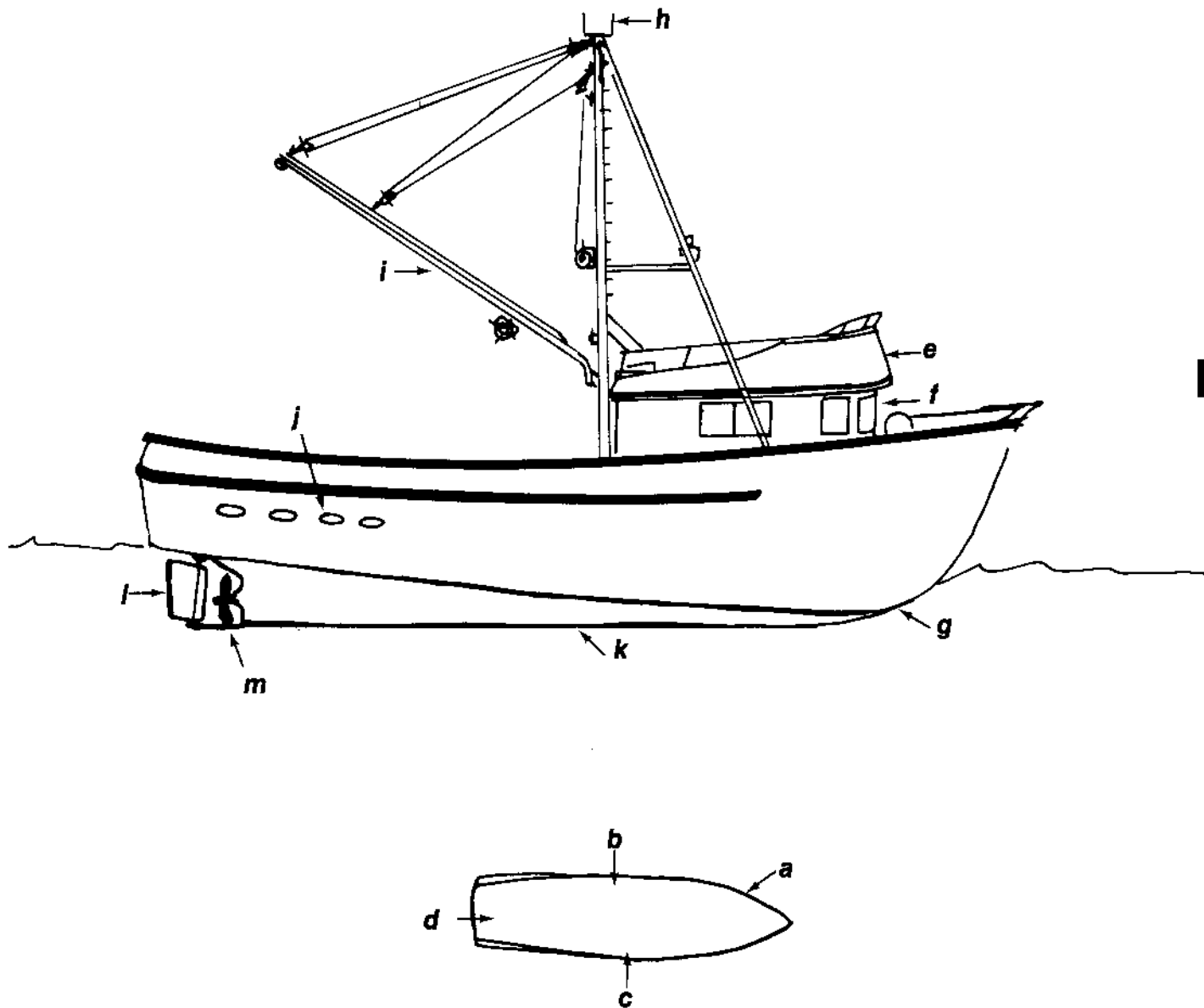

- Keel - a timber or plate running lengthwise along the center bottom of a boat.
- Hull - the outer covering of the main part of a boat.
- House - the cabin or living space built above the deck and hull.
- Mast - a long pole rising from the deck of a boat and used to support various rigging.
- Boom - a long pole that extends horizontally from the mast. It may be used to hold the bottom of a sail or to support gear or rigging.
- Bow - the forward part of the boat.
- Stern - the aft, or rear, part of the boat.
- Port - the left hand side of the boat if you are facing toward the bow.
- Starboard - the right hand side of the boat if you are facing toward the bow.
- Rudder - a "board" below water level at the stern of the boat. Changing its position mechanically makes the boat turn or change direction.
- Propeller - a blade-bearing device which powers turns and by its motion, moves the boat.
- Crow's Nest - lookout point at the top of the mast.
- Scuppers - holes that allow water to drain off the deck.
- Flying Bridge - the location from which a boat is steered and its speed controlled.

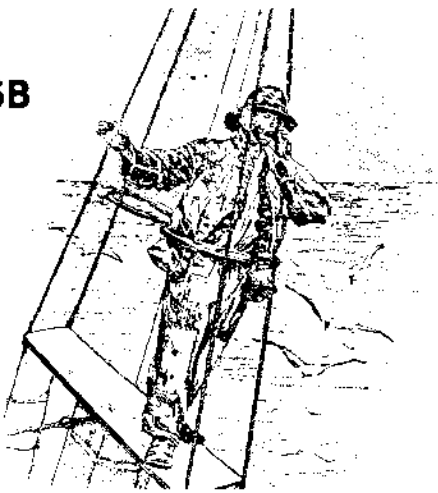

# Ship Ahoy!

Stow that landlubber chatter and try your hand at becoming an old salt!

Put the letter of the landlubber meanings in front of the old salt sayings.

LANDLUBBER		OLD SALT
a. Park the boat.	_____	1. Cast off, matey.
b. Come on in.	_____	2. Haul on that line.
c. Secure the doors.	_____	3. Get below.
d. Go downstairs	_____	4. Swab the deck.
e. Untie the ropes and let's go.	_____	5. Use the head.
f. Go to bed.	_____	6. Pump the bilges.
g. Drain the basement.	_____	7. Roll into your bunk.
h. Life preservers are in the back.	_____	8. Man the helm.
i. Pull that rope.	_____	9. Stow your gear.
j. Wash the floor.	_____	10. Welcome aboard.
k. Drive the boat.	_____	11. Make fast to the dock.
l. Go to the bathroom.	_____	12. She's listing to the starboard.
m. Put your clothes away.	_____	13. Go aloft.
n. Get up above.	_____	14. P.F.D.'s are aft.
o. Put everything in good order.	_____	15. Make everything shipshape.
p. The boat's leaning to the right.	_____	16. Batten down the hatches.

# Port of Anchorage Chart

from ALASKA Tidelines

Nautical charts are the road maps of the sea. They tell you how deep the water is and what the bottom is like. They warn you of rocks, reefs, mud flats and other hidden hazards. And they show the signposts you need, such as lights, bells, buoys, and landmarks on shore.

The waters of Cook Inlet are so tricky that a special pilot is required on all large vessels traveling north of Homer. But there's no law against a little desktop navigation. So study the legend in the lower right-hand corner and steer yourself safely into port.

1. In the lingo of the sea, starboard is to your right as you face the front of your boat, and port is to your left. (An easy way to remember: "port" and "left" have the same number of letters.) So from your boat's position shown on the chart, Moose Point is on your \_\_\_\_\_ side and the lighted (oil) platform is on your \_\_\_\_\_ side.
2. The Inlet bottom right about there is generally \_\_\_\_\_ and \_\_\_\_\_.
3. Moving right along, you have reached the buoy in the middle of the Inlet north of Point Possession. Water depth is usually measured by the fathom, which is equal to six feet. The chart shows the water depth here is 11 fathoms. How many feet is that? \_\_\_\_\_
4. When heading in from the sea, the general rule is to keep red buoys and even numbers on your starboard side, and green lights or black buoys with odd numbers on your port side. (Remember: "red-right-returning.") So you want to keep that buoy on your \_\_\_\_\_ side.
5. Now you're off Fire Island and lined up with the beacon lights on Point MacKenzie. (Note the solid and dotted lines on the chart which show the recommended route into port.) How high is the top light? \_\_\_\_\_  
What does "E Int 6sec" mean? \_\_\_\_\_
6. Getting close! Keep that N "2" buoy to your \_\_\_\_\_ side.
7. The Port of Anchorage is in sight and you're on your own. Your vessel draws (needs) 36 feet of water. So check the fathom markings (this chart shows depths at average low low tide) and draw a line to plot your course to the dock.

5C

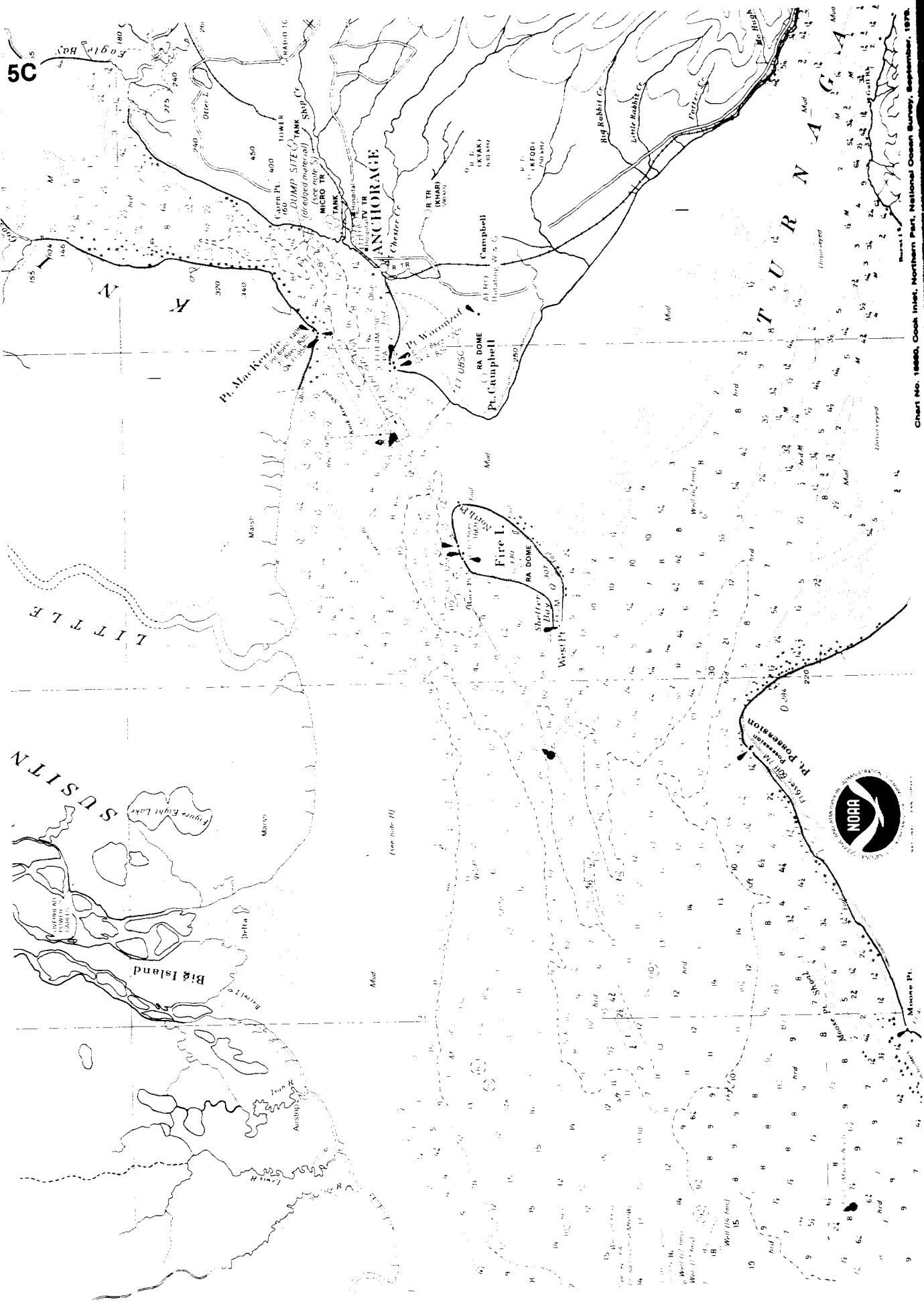

Chart No. 16880, Cook Inlet, Northern Part, National Ocean Survey, September, 1978.

## LEGEND

All soundings (depths) are in fathoms (6 feet) at mean (average) lower low tide.

.....	less than 10 fathoms
-----	10 fathoms or more
MHHW	mean higher high water
MLLW	mean lower low water





Bottom

hrd	hard
rky	rocky
stk	sticky
sft	soft
SPSt	sand, pebbles, stones
gySP	gray sand, pebbles

Hazards

+	sunken rock
*	rocks that cover & uncover with tides

Buoys & Beacons

	buoy (lighted)
	buoy (unlighted)
	beacon (land)
	RA (radar dome)
	R TR (radio tower)
N	"nun" (black buoy)
C	can buoy
"2"	number on buoy
R	red
G	green
Fl	flashing
Qk	quick
E	equal
Int	intervals
sec	seconds
ft	feet above water at high tide
M	nautical mile (distance can be seen)
PA	position approximate
obst	obstruction
LTOBSC	light obscured

# Nautical Knots

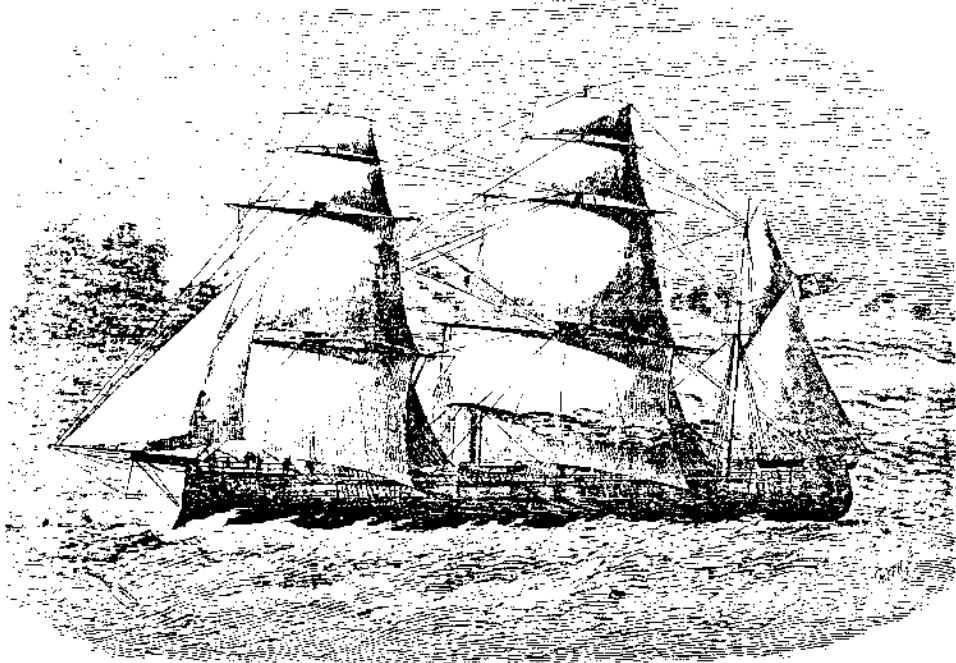

A knot is something you tie, but also a way of measuring how fast a boat travels! On land we talk about how many miles per hour a car or snowmobile can go. On water, if a boat is moving at one knot, it is traveling one nautical mile per hour. A nautical mile is a little longer than a land mile. So if a boat goes at a speed of 8 or 9 knots, it is traveling at about the same speed as 8 or 9 miles per hour. Not very fast on land but a good speed for a boat!

1 knot - 1 nautical mile per hour

Try these knotty problems.

1. If your boat travels 45 nautical miles to get to the fishing grounds at a speed of 9 knots, how long will it take to get there? \_\_\_\_\_
2. To travel from one fishing spot to another, your boat travels for 10 hours at a speed of 7 knots. How many nautical miles did your boat travel?  
\_\_\_\_\_
3. Coming back to port, your fishing boat traveled five hours and went a total distance of 30 nautical miles. At what speed (how many knots) was it traveling?  
\_\_\_\_\_
4. If fuel costs \$1.50/gal. and your engine averages 3 knots/gallon, how much did your 30 nautical-mile trip back to port cost? \_\_\_\_\_
5. Now make up your own knotty problem and exchange it with your neighbor to see if he or she can do it!

# Eight Knots

Directions: Practice typing these knots until you can tie them blindfolded. Sometime you may need to tie them fast, at night, in cold weather.



**FIGURE EIGHT**  
Use to keep the end of a line from unraveling or as something to hold onto.

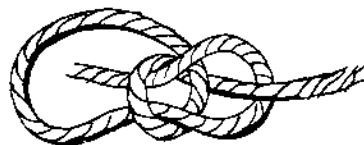

**BOWLINE** (pronounced bölyn)  
Use to tie a non-slip loop at the end of a line. The bowline does not jam and can be untied.



**SHEET BEND**  
Use to tie two uneven lines together.



**TWO HALF HITCHES**  
Use to make a line fast to a piling or a ring.

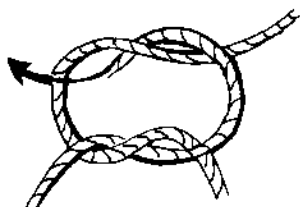

**SQUARE KNOT**  
Use to tie two light lines of the same size together. (Be sure that the line going into one side on top is going out on top as it comes back through--otherwise it's a granny knot and won't hold!)

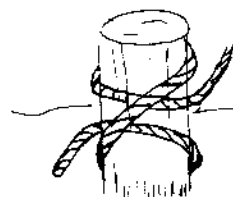

**CLOVE HITCH**  
Use to make a line fast temporarily to a piling. (Be sure you push the top and bottom together, or it won't hold!)



**FIGURE EIGHT ON A CLEAT**  
Use to tie to a cleat. (Make sure the line is wrapped around the base of the cleat first.)



**FISHERMEN'S BEND**  
Use to make fast to a buoy or the ring of an anchor. This knot is also called the anchor bend.



# Tides

Tides involve the rising, and lowering and movement of great masses of water. People fishing watch the tides almost as closely as people living on land might watch a clock. Boats can go dry or float away, depending on the tides. Channels can be too shallow to get through on a low tide. Fishing is often best on a rising tide.

If water is moved through a narrow opening by the tides, a tidal may be very evident. In fact, it may be so strong that a boat cannot move against it even at full power. Even on the coast of the open ocean, tidal currents are sometimes very strong. People traveling from one place to another by boat, they try to time their travels in such a way as to be going in the same direction as the tidal current. That gives them a faster trip and saves on fuel. A great deal of where and when and how a person fishes depends on the strength and direction of the tidal currents.

Knowing how to read a tide book is important. The main part of a tide book gives the time and height of the tides for every day of the year for several main locations. Additional pages of corrections enable the reader to figure out the same kinds of information for other nearby places.

On the following page are two pages from a tide table. Look at them, and notice there are two low tides and two high tides on most days. Then answer the following questions.

1. On November 1, how high is the highest tide in Cordova?  
\_\_\_\_\_
2. On November 1, how low is the lowest tide in Cordova?  
\_\_\_\_\_
3. What time are the high tides in Cordova on November 15?  
\_\_\_\_\_ and \_\_\_\_\_
4. What time are the low tides in Cordova on November 22?  
\_\_\_\_\_ and \_\_\_\_\_
5. On what day in November is the lowest tide of the month in Cordova? \_\_\_\_\_
6. On what day in November is the highest tide of the month in Cordova? \_\_\_\_\_
7. On November 16, what is the difference in the height of the water when the tide is at its lowest and when it is at its highest? \_\_\_\_\_

# Tide Tables

## HIGH Tides CORDOVA District NOVEMBER 1983

DATE	DOT'S	A. M.	P. M.
DAY	GUIDE	TIME	TIME
		FT.	FT.
1	Tues ●	9:36 12.7	9:49 12.2
2	Wed ●	10:16 13.6	10:42 12.6
3	Thur ●	10:56 14.4	11:33 12.9
4	Fri ●	11:32 14.8	-----
5	Sat ●	0:19 12.9	12:07 15.0
6	SUN ●	1:03 12.7	12:42 14.8
7	Mon ●	1:45 12.2	1:15 14.3
8	Tues ●	2:31 11.6	1:49 13.5
9	Wed ●	3:13 10.9	2:26 12.5
10	Thur ●	4:09 10.2	3:08 11.4
11	Fri ●	5:18 9.7	4:04 10.3
12	Sat ●	6:32 9.6	5:34 9.5
13	SUN ●	7:34 9.8	7:03 9.3
14	Mon ●	8:21 10.4	8:13 9.6
15	Tues ●	8:59 11.0	9:06 10.0
16	Wed ●	9:33 11.7	9:54 10.5
17	Thur ●	10:07 12.5	10:42 10.9
18	Fri ●	10:39 13.2	11:24 11.4
19	Sat ●	11:09 13.8	-----
20	SUN ●	0:07 11.7	11:44 <sup>A</sup> 14.3
21	Mon ●	0:47 11.8	12:17 14.5
22	Tues ●	1:30 11.8	12:53 14.5
23	Wed ●	2:13 11.6	1:30 14.2
24	Thur ●	3:03 11.2	2:15 13.6
25	Fri ●	4:00 10.8	3:07 12.6
26	Sat ●	5:12 10.7	4:21 11.5
27	SUN ●	6:21 10.9	5:56 10.7
28	Mon ●	7:23 11.5	7:22 10.5
29	Tues ●	8:14 12.3	8:35 10.6
30	Wed ●	9:02 13.1	9:38 10.9

● BIGGER THE DOT—BETTER THE FISHING

## LOW Tides CORDOVA District NOVEMBER 1983

DATE	DOT'S	A. M.	P. M.
DAY	GUIDE	TIME	TIME
		FT.	FT.
1	Tues ●	3:06 0.9	3:43 1.7
2	Wed ●	3:54 0.5	4:31 0.0
3	Thur ●	4:40 0.4	5:14 -1.3
4	Fri ●	5:19 0.6	5:56 -2.1
5	Sat ●	5:59 1.1	6:36 -2.4
6	SUN ●	6:36 1.9	7:16 -2.1
7	Mon ●	7:15 2.8	7:55 -1.5
8	Tues ●	7:54 3.8	8:37 -0.5
9	Wed ●	8:39 4.8	9:21 0.5
10	Thur ●	9:24 5.6	10:09 1.6
11	Fri ●	10:20 6.2	11:05 2.5
12	Sat ●	11:28 6.5	-----
13	SUN ●	0:09 3.1	12:56 6.1
14	Mon ●	1:23 3.2	2:23 5.1
15	Tues ●	2:24 3.0	3:16 3.7
16	Wed ●	3:14 2.7	3:57 2.3
17	Thur ●	3:54 2.4	4:31 0.9
18	Fri ●	4:31 2.2	5:08 -0.3
19	Sat ●	5:03 2.1	5:40 -1.3
20	SUN ●	5:39 2.3	6:19 -1.9
21	Mon ●	6:17 2.6	6:57 -2.1
22	Tues ●	6:53 3.1	7:39 -2.0
23	Wed ●	7:38 3.6	8:25 -1.6
24	Thur ●	8:26 4.2	9:16 -0.9
25	Fri ●	9:21 4.7	10:09 -0.2
26	Sat ●	10:27 4.9	11:09 0.6
27	SUN ●	11:41 4.8	-----
28	Mon ●	0:15 1.3	1:05 4.0
29	Tues ●	1:23 1.7	2:25 2.6
30	Wed ●	2:29 1.9	3:27 1.0

STANDARD TIME

# Putting Out to Sea

Working at sea is tough and dangerous, and much of the hazard comes from the sea itself. Alaskan waters, for example, are so cold that, unprotected, a person can survive no longer than 30 minutes before becoming unconscious. In addition to the cold water, sudden storms and winds can whip seas into huge waves capable of endangering even the largest and strongest of vessels.

Modern equipment has helped make boating and fishing safer, but the most important part of being safe is still to be very cautious and to know and understand as much as possible about winds, weather and the ways of the sea. Eskimo hunters sometimes travel far from land in small boats, but they carefully watch changes in the sky, the wind and the sea and know what even the slightest changes mean to them and their safety. People traveling the rivers of Interior Alaska must know the swift parts of the river where currents or eddies are dangerous and the shallow places. People fishing salmon or halibut on the open sea must always carefully calculate how long they dare stay out and fish if the weather is deteriorating. They must know when to run for shelter of safe bays or other anchorages along the coast.

Here is a list of equipment needed for a safe voyage. Draw a picture of a boat that you would like to own and show and LABEL the safety equipment you'll need.

1. A stout boat. Any boat that goes to sea should be strong, in good shape, and free of leaks or rot that will make it weak.
2. A radio. Many boats have two kinds of radios. A citizens band radio, or CB, can be used for talking over short distances, such as to a boat fishing nearby. A very high frequency radio, or VHF, is used for talking over longer distances. With a VHF radio, a person can make ship-to-shore, long-distance phone calls; can get up-to-date weather forecasts; or can call the U.S. Coast Guard if there is an emergency and help is needed. On a small boat, a regular transistor radio can be used to listen to periodic weather forecasts. Be sure and check the weather forecast before even starting your trip!

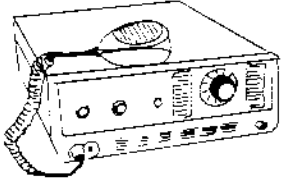

3. Life preservers and/or survival suit. By law every boat is required to have one approved life preserver or P.F.D. (personal floatation device) for each person on the boat. Many fishing boats carry survival suits as well. Survival suits are like loose fitting diving suits. They are made out of neoprene rubber and insulate a person's body from icy waters. With a survival suit, a person can stay alive in the open sea for several days awaiting rescue.

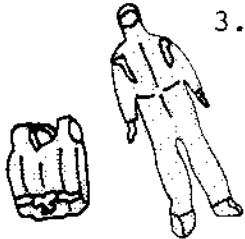

4. Life ring and line. These should always be handy to throw to anyone who falls overboard because sometimes it takes awhile to turn the boat around.

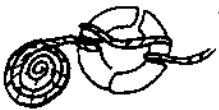

5. Survival gear. If you're tossed on shore in an open life boat, survival gear can be most helpful! Wrap a spare sleeping bag in a waterproof bag or plastic bags together with a survival kit containing food, matches, flares, propane lighters, signal mirror, fishing line and hooks, tarp or pieces of plastic, water, etc.

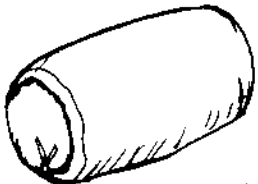

6. Life raft. Some life rafts store in small containers and automatically inflate and release if the vessel sinks. The life raft will give shelter and help conserve the body heat of people who have abandoned their boats at sea. Be sure to store emergency food and water with the raft and have the raft checked every so often to make sure it will still inflate!

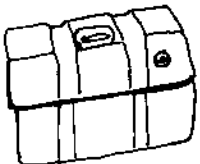

7. Fire extinguishers. Surrounded by water on a boat, there may be no way to put out a fire unless there is an extinguisher that will put out electrical or chemical fires.



8. Bilge pump or bailer. Water does sometimes come inside boats, and it's very important to be able to get rid of it quickly! Larger boats require bilge pumps. Always have a spare handy too! Smaller boats can use a bucket or can for bailing.
9. Radar. Having radar is like having eyes that can see in the fog or the dark. With radar, a person on a boat can watch at night for other nearby boats, can see icebergs ahead or large floating logs that might damage the vessel. The operator can also see the shape of a river, the outline of a coast and can measure the distance from the boat to any of these. Many fishermen these days are buying Loran systems as an alternative radar. Courses can be programmed so boats can get through channels in the dark. Loran utilizes the differences in two radio pulses to determine position.
10. Fathometer. This instrument shows the depth of the water. Water depth changes with the tide and fishermen must often be careful of where and when they cross shallow areas. No one wants to end up high and dry on a mud flat or a reef. People fishing often use a recording fathometer that provides depths on a long sheet of paper. This kind of fathometer will tell how deep the water is under the boat and will record small black marks for every fish passing beneath the boat.
11. Horn, whistle and/or bell. In times of poor visibility, some sort of warning is needed to keep vessels from running into each other. The Coast Guard has outlined rules of the road for different situations. The danger signal is four short blasts.
12. Charts. No one should set out in a boat without having a good chart of the area--either inside his head or on paper. Charts for all coastal areas are put out by the United States government. They show depths, hazards, harbors--everything that is known about a particular piece of coast line. The government also puts out a book called The Coast Pilot that describes coastal features shown on the charts.
13. Compass. Under conditions of poor visibility, there may no other way to keep track of where you are.
14. Anchor. If any vessel is in distress, it may drift into shallow water where an anchor can hold it securely and prevent it from being tossed on a rocky shore. And when you anchor, be sure you attach even line to allow for a rising tide!

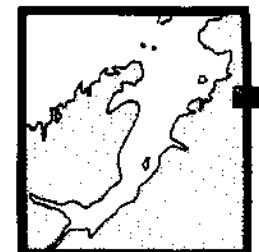
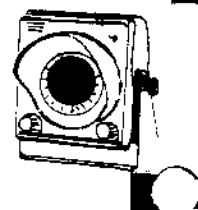
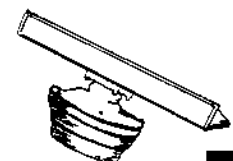
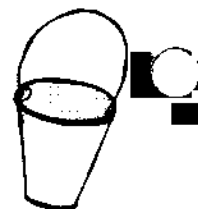



15. Tools, spare parts, and a spare motor. Many times whether you get back before dark will depend on your mechanical ability, tools, parts, and a spare motor!

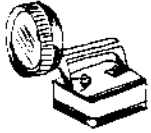

16. Lights and spare batteries. If you need to attract attention, work on your motor in the dark, anchor your boat at night, or find the channel, lights are very necessary. When running at night, boats should show a red light on the port side and a green light on the starboard, plus white lights on the bow and/or stern depending on the size of vessel.



17. Oars. Every motorboat should have oars and spare oars aboard. A motor can always quit or run out of gas. Then oars and muscle power become important.



18. First aid kit. Basic supplies include bandages, antiseptic and burn ointments, lotions, aspirin, bandaids, tape, scissors, tweezers, thermometer, safety pins, cotton, and a first aid book!

19. Sailing plan. Always leave word of where you're going and your planned date and time of return with your family, friends or the harbor master, so they'll know where to look if you fail to return.

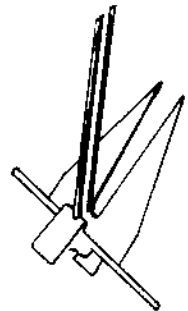
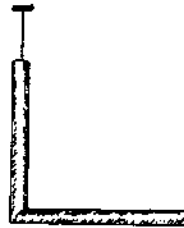
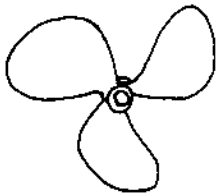
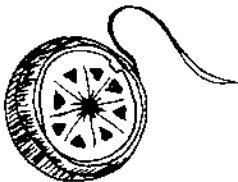

# The Safety Afloat Game

To the Teacher:

Make four copies of this sheet. Back sheets with tagboard. Carefully cut out each Safety Device and glue to end of a cocktail swizzle or similar small stick. Back playing board on tagboard, cover with clear laminate if possible. Store Safety Devices in an envelope.

Objective of the game is to enable students to identify by sight and name the Safety Devices needed aboard boats.



Approved  
Fuel Tanks



Sailing  
direction and  
Return time  
left with  
harbor master



Bouyant  
materials to  
throw over board  
for rescue.



Lights and  
extra batteries



Fire Extinguisher(s)



P.F.D.  
Personal Floatation  
Device



Mooring Lines  
for mooring  
for Rescue  
Retrieval.



Bailing Bucket



Radar Finder



First Aid Kit and Manual  
(Marine type)



Extra Oars  
or  
Paddles

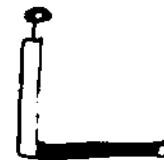

Bilge Pump



Boat Hook\*

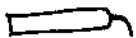

Flares or other  
distress signals.



Food and Water  
Rations



Transister  
Radio



Anchor



Bell



Horn or Whistle



Tool Kit



Spare Parts

\*Playing Piece for each player to use.

boats

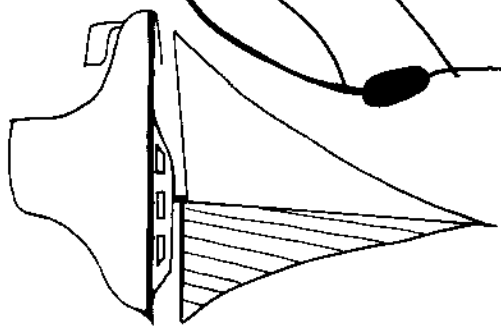

ferry

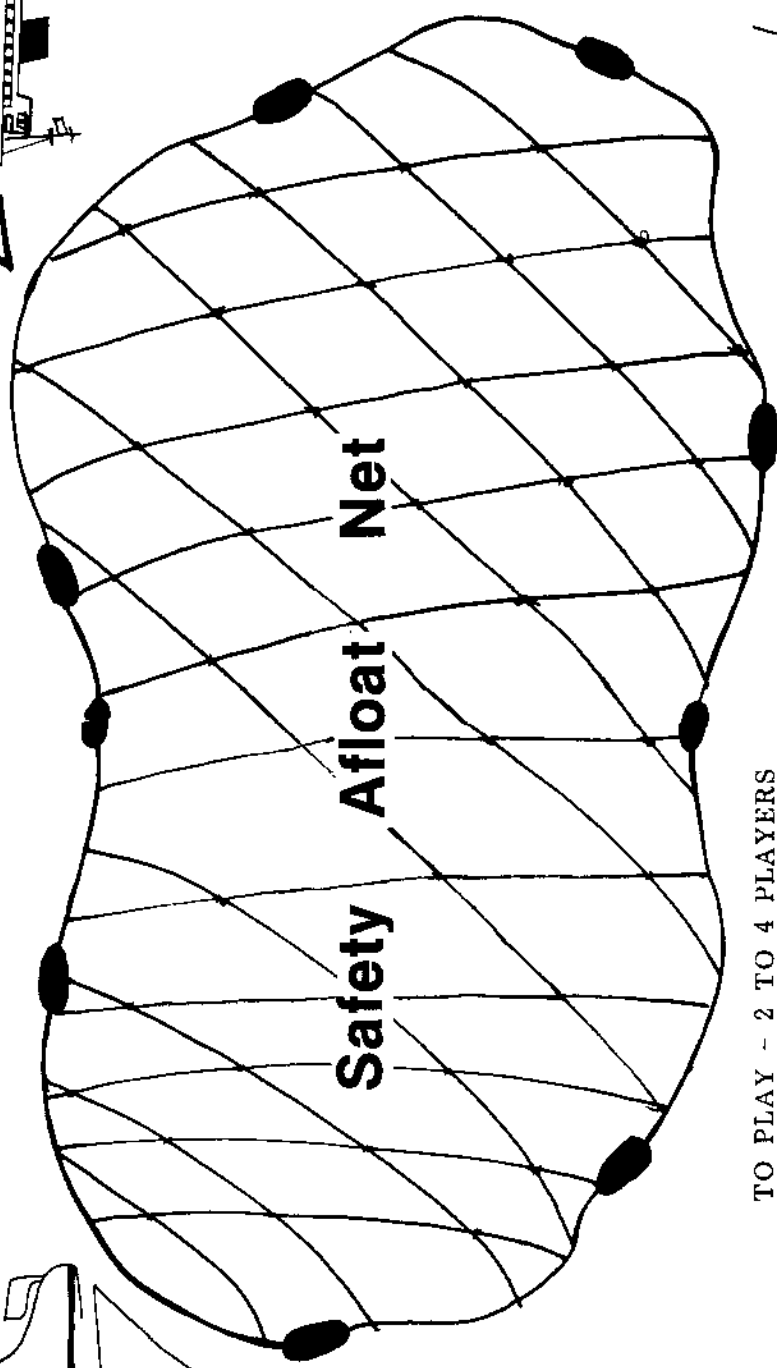
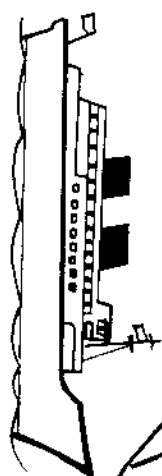

TO PLAY - 2 TO 4 PLAYERS

1. Place Safety Devices in hand and release in pile in the Safety Afloat Net.
2. Each player in turn removes as many Safety Devices as possible without moving any but the intended one.
3. Each time a player must name the Safety Device before attempting to remove it. A single plain "boat hook" is used for each player who places all "caught" safety devices on his "ship."
4. Play is terminated when any Safety Device other than the one intended moves. At the end of each turn, one Safety Device must be returned to the net.
5. Play ends when one player has one of each device aboard.

runabout



trawler

